

ITEM NO.	PART NUMBER	QTY.
1	Running Gear Frame	1
2	Rim 10X15 for 12L-15	4
3	12L-15	4
4	Tongue	1
5	Tongue Mount with balls	1
6	Connecting Rod for Ball Joint	2
7	Running Gear Spindle 2	2

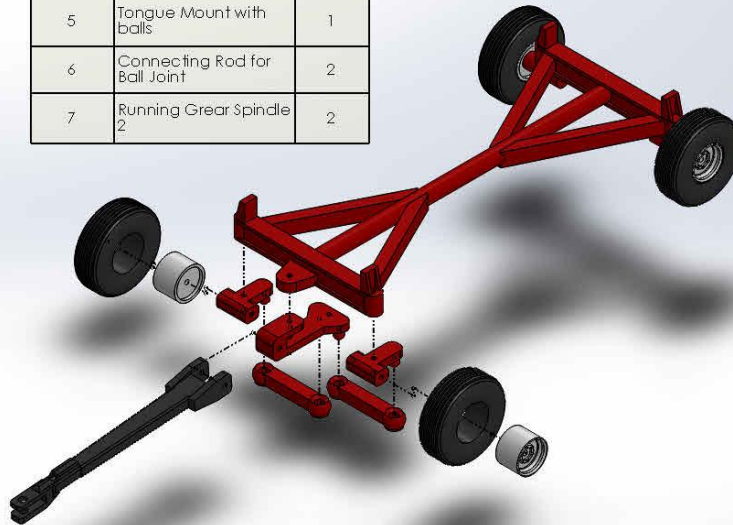

1. Inspect all parts and sand or file any burrs or imperfections.
2. Prepare parts for painting by washing in water with a drop of dishwashing liquid. This will remove any oil residue and allow paint to adhere properly.
3. Drill out the holes for axles/pins with a .025 drill bit. Mount center pivot point as shown in drawing. After pin is through whole apply small amount of glue to outside to allow for movement. Do the same for each axle pivot.
4. Mount tires on rims. May need to sand for proper fit.
5. Slide pin through rim, cut off excess, apply glue to end of pin and insert into drilled whole.
6. Install tie rods from center pivot to wheel axle pivots, be sure the ball and socket is clean and free of burrs. Using fingers or a small needle nose plyers gently push the socket onto the ball until it clicks into place.